



Liquid Turbine Flow Meter

Content

1.0 GENERAL INFORMATION	1
2.0 SPECIFICATIONS	2
3.0 OPERATION CONDITIONS.....	3
4.0 MODEL AND SELECTION.....	4
5.0 CAUTIONS FOR INSTALLATION.....	6
6.0 ELECTRICAL WIRING	10
7.0 OPERATION AND SETUP	12
8.0 TROUBLESHOOTING.....	13
9.0 METER CONSTRUCTION.....	14



Warning

When the Flowmeter is installed at explosion hazard field, **DON'T remove the COVERPLATE when the meter is powered.** Please make parameter setting at safe filed prior to installation.

For LWGY-B (Battery Powered Type) and LWGY-C (24V DC Power), it's optional to use one special magnet for totalizer reset. Please request this function when totalizer reset is frequently used at hazard field.



Special Notice

Pictures & Descriptions are for your information only, please refer to the actual product. Parameters are subjected to changes without notice.

1.0 GENERAL INFORMATION

This manual will assist you in installing, using and maintaining your Lekton turbine flow meter. It is your responsibility to make sure that all operators have access to adequate instructions about safe operating and maintenance procedure.



Warning

For your safety, review the major warnings and cautions below before operating your equipment.

1. Use only fluids that are compatible with the housing material and wetted components of your turbine.
2. When measuring flammable liquids, observe precautions against fire or explosion.
3. When handling hazardous liquids, always follow the liquid manufacturer's safety precautions.
4. When working in hazardous environments, always exercise appropriate safety precautions.
5. During turbine removal, liquid may spill. Follow the liquid manufacturer's safety precautions for clean up of minor spills.
6. Do not blow compressed air through the turbine.
7. Handle the rotor carefully. Even small scratches or nicks can affect accuracy.
8. When tightening the turbine, use a wrench only on the wrench flats.
9. For best results, calibrate the meter at least 1 time per year.

Product Description

LWGY series turbine flow meters have the features: high accuracy, good repeatability, convenient installation/maintenance, simple structure etc.

Liquid flows through the turbine housing causing an internal rotor to spin. As the rotor spins, an electrical signal is generated in the pickup coil. This signal is converted into engineering units (liters, cubic meters, gallons etc.) on the local display where is applicable. Optional accessory modules can be used to export the signal to other equipment.

Upon receipt, examine your meter for visible damage. The turbine is a precision measuring instrument and should be handled carefully. Remove the protective plugs and caps for a thorough inspection. If any items are damaged or missing, contact Lekton

Make sure the turbine flow model meets your specific needs. For your future reference, it might be useful to record this information on nameplate in the manual in case it becomes unreadable on the turbine. Refer to the nameplate for your customized product's specification.

2.0 SPECIFICATIONS

Performance

Repeatability:	±0.2%
Accuracy:	Standard: ±1% of reading; Optional: ±0.5% of reading

Wetted Components

Housing:	Standard - 304 Stainless Steel Optional - 316 Stainless Steel
Bearings and Shaft:	Tungsten Carbide
Rotor:	Standard - 2Cr13 Stainless Steel (Optional Alloy CD4Mcu)
Retaining Rings:	316 Stainless Steel

Output Signal: (Where applicable)

Sensor:	Pulse signal (Low Level: 0.8V; High Level: 8V)
Transmitter:	4 to 20 mA DC current signal

Signal Transmission Distance: 1,000 m

Electrical Connections:

Basic Type:	Hausman Connector or three-core cable
Explosion Proof Type:	ISO M20×1.5 Female

Explosion Proof Level:

Standard:	None
Optional:	ExdIIBT6

Protection Level: IP65

3.0 OPERATION CONDITIONS

Ambient:

Temperature:	-10°C to +55°C
Pressure:	86 to 106 KPa
Relative Humidity:	5% to 90%

Power Supply:

Sensor:	+12V DC (Optional: +24V DC)
Transmitter:	+24V DC
Field Display Type B:	Integral 3.2V Lithium Battery (Others available on request)
Field Display Type C:	+24V DC

Fluid Temperature and Pressure:

Temperature:	-20°C to +110°C
Pressure:	Fluid pressure should be limited according to rating.

Measurable Flow Rate Range and Pressure Level: (See table 1)

Table 1. Measurable Flow Range and Pressure Rating

Nominal Diameter		Standard Flow Range (SFR)	Extended Flow Range (EFR)	Standard Pressure Rating	Customized Pressure Rating
(mm)	(in.)	(m ³ /h)	(m ³ /h)	(MPa)	(MPa) - Flange Fitting
4	0.15	0.04 to 0.25	0.04 to 0.4	Thread: 6.3	12, 16, 25
6	0.25	0.1 to 0.6	0.06 to 0.6	Thread: 6.3	12, 16, 25
10	0.4	0.2 to 1.2	0.15 to 1.5	Thread: 6.3	12, 16, 25
15	0.5	0.6 to 6	0.4 to 8	Thread: 6.3; Flange: 2.5	4.0, 6.3, 12, 16, 25
20	0.75	0.8 to 8	0.45 to 9	Thread: 6.3; Flange: 2.5	4.0, 6.3, 12, 16, 25
25	1	1 to 10	0.5 to 10	Thread: 6.3; Flange: 2.5	4.0, 6.3, 12, 16, 25
32	1.25	1.5 to 15	0.8 to 15	Thread: 6.3; Flange: 2.5	4.0, 6.3, 12, 16, 25
40	1.5	2 to 20	1 to 30	Thread: 6.3; Flange: 2.5	4.0, 6.3, 12, 16, 25
50	2	4 to 40	2 to 40	Flange: 2.5	4.0, 6.3, 12, 16, 25
65	2.5	7 to 70	4 to 70	Flange: 2.5	4.0, 6.3, 12, 16, 25
80	3	10 to 100	5 to 100	Flange: 2.5	4.0, 6.3, 12, 16, 25
100	4	20 to 200	10 to 200	Flange: 1.6	4.0, 6.3, 12, 16, 25
125	5	25 to 250	13 to 250	Flange: 1.6	2.5, 4.0, 6.3, 12, 16
150	6	30 to 300	15 to 300	Flange: 1.6	2.5, 4.0, 6.3, 12, 16
200	8	80 to 800	40 to 800	Flange: 1.6	2.5, 4.0, 6.3, 12, 16

4.0 MODEL AND SELECTION

Model

4.1 Turbine Flow Sensor/Transmitter

LWGY- N Type Sensor: 12 to 24V DC Power Supply; Pulse Output

LWGY- A Type Transmitter: 24V DC Power Supply; 2-wire 4 to 20 mA Output

Basic Type (Without Explosion Proof) and Explosion Proof Type are optional for LWGY- N and LWGY- A.



Basic Type



Explosion Proof Type

4.2 Intelligent Integrated Turbine Flow Meter (Refer to photo on page 1)

4 digital instantaneous flow display

8 digital totalizer flow display (Resettable)

With Explosion Proof (Level: ExdIIBT6)

3-Point Correction and Non-linearity Compensation on K-Factor

Note: The K-Factor represents the number of output pulses transmitted per cubic meter (Optional: Liter and Gallons) of fluid passing through the turbine meter. Each turbine has a unique K-Factor. However, turbine meters are not functionally consistent throughout the full flow range of the meter. Therefore, correction and non-linearity compensation on K-Factor can enhance accuracy.

LWGY- B Type: powered with 3.2V10AH lithium battery (Battery life > 3 years); no output

LWGY- C Type: 24V DC Power Supply; 2-wire 4 to 20 mA Output (Optional: RS485 or HART)

Model Selection (See Table 2)

Table 2. Model Selection Guidance

Model Suffix Code								Description (SFR: Standard Flow Range)
LWGY-		/	/	/	/	/	/	
Nominal Diameter (mm)	4							4mm; SFR: 0.04 to 0.25 m ³ /h
	6							6mm; SFR: 0.1 to 0.6 m ³ /h
	10							10mm; SFR: 0.2 to 1.2 m ³ /h
	15							15mm; SFR: 0.6 to 6 m ³ /h
	20							20mm; SFR: 0.8 to 8 m ³ /h
	25							25mm; SFR: 1 to 10 m ³ /h
	32							32mm; SFR: 1.5 to 15 m ³ /h
	40							40mm; SFR: 2 to 20 m ³ /h
	50							50mm; SFR: 4 to 40 m ³ /h
	65							65mm; SFR: 7 to 70 m ³ /h
	80							80mm; SFR: 10 to 100 m ³ /h
	100							100mm; SFR: 20 to 200 m ³ /h
	125							125mm; SFR: 25 to 250 m ³ /h
	150							150mm; SFR: 30 to 300 m ³ /h
	200							200mm; SFR: 80 to 800 m ³ /h
Type	N							Basic Type: +12V to +24V DC Power Supply; Pulse Output
	A							4 to 20 mA current output
	B							Battery Power Supply with filed Display
	C							Field Display and 4 to 20 mA current output
	C1							Field Display and RS485
	C2							Field Display and HART
Accuracy Rating	10							±1.0% of reading
	05							±0.5% of reading
Measurable Range	S							Standard: Refer to table 1
	E							Extended: Refer to table 1
Housing Material	S							304 Stainless Steel
	L							316 (L) Stainless Steel
Explosion Rating								Blank: without Explosion Proof
	E							Explosion Proof: ExdIIBT6
Pressure Rating	N							Standard: Refer to table 1
	H(x)							Customized: Refer to table 1

5.0 CAUTIONS FOR INSTALLATION

Mounting Positions

Turbine flow meters should be installed at the place in compliance with the requirements below:

Easy maintenance

No vibration

No electromagnetic interface

Away from heat source

Mounting Orientation

All SURE turbine flow meters are designed to measure flow in only one direction. The direction is indicated by the arrow on the body.

Required Lengths of Straight Runs

Flow altering device such as elbows, valves and reducers can affect accuracy. See diagram 1 for typical flow meter system installation.

Diagram 1. Typical Flow Meter System Installation

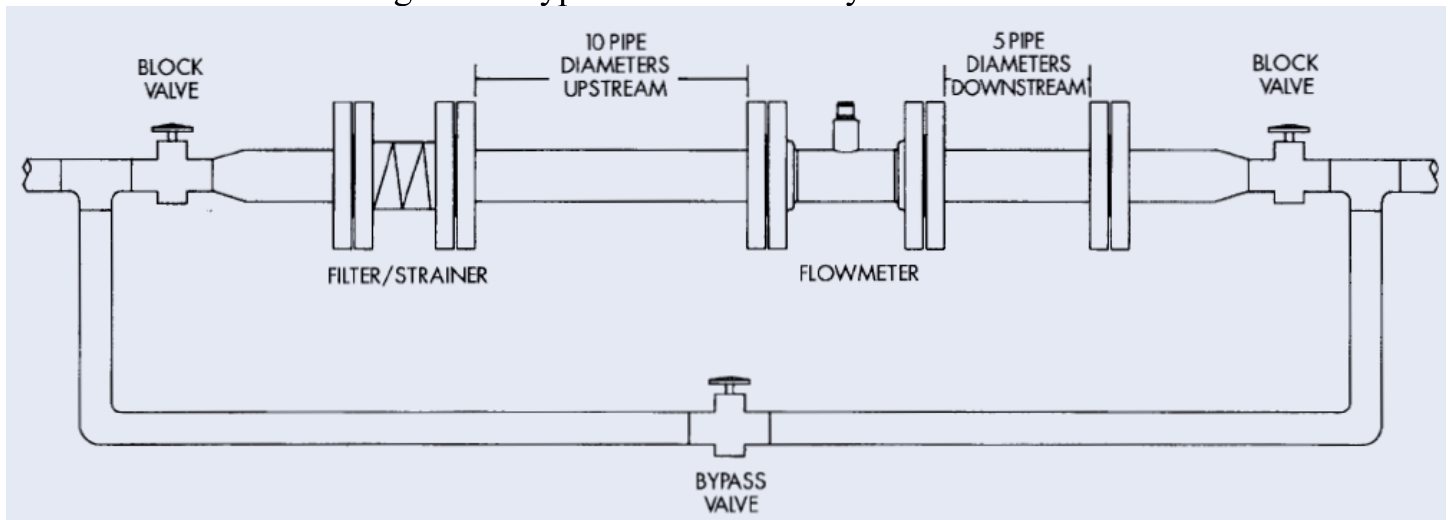

The recommended guidelines are given to enhance accuracy and maximize performance. Distance given here are minimum requirements; double them for desired straight pipe lengths.

- 👉 Upstream: allow a minimum straight pipe length at least 10 times the internal diameter of the pipe. For example, with the 50mm pipe, there should be 500mm of straight pipe immediately upstream. Desired upstream straight pipe length is 1000mm.
- 👉 Downstream: allow a minimum straight pipe length at least 5 times the internal diameter of the pipe. For example, with the 50mm pipe, there should be 250mm of straight pipe immediately upstream. Desired upstream straight pipe length is 500mm.

See diagram 2 for straight pipe length requirement when there is altering device.

Diagram 2. Number of Pipe Diameter (D=Diameter)

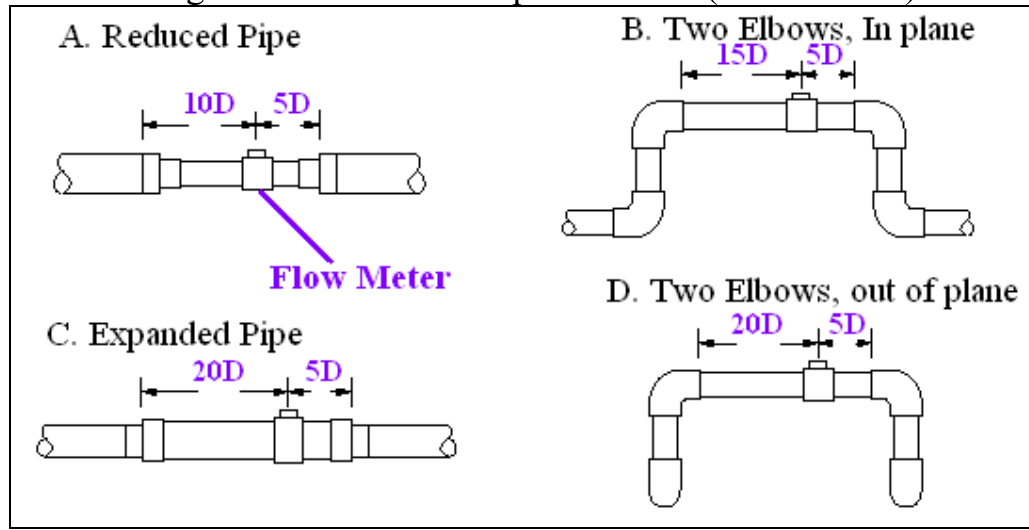

Warning: Precaution for direct sunshine and rain when the meter is installed outside.

Anti-Cavitation

Cavitation can be caused by entrained air, and it can seriously damage the rotor on a turbine flow meter. An amount higher than about 100 mg/l of entrained air or gas can produce error. In addition, cavitation can be caused by too little backpressure on the flow meter. For SURE turbine flow meters, you should provide a backpressure (downstream pressure) of at least 1.25 times the vapor pressure, plus 2 times the pressure drop through the flow meter. See formula 1.

$$\text{Formula 1: } P_b = 1.25 \times P_v + 2 \times (P_{in} - P_{out})$$

In formula 1: (P_b : Back pressure; P_v : Vapor Pressure; P_{in} : Inlet Pressure; P_{out} : Outlet Pressure)

Create backpressure by installing a control valve on the downstream side of the meter at the proper distance detailed above.



Special Notice

Foreign material in the liquid being measured can clog the meter's rotor and adversely affect accuracy. If this problem is anticipated or experienced, install screens to filter impurities from incoming liquids.



To ensure accurate measurement, drain all air from the system before use.



When the meter contains removable coverplates. Leave the coverplate installed unless accessory modules specify removal. Don't remove the coverplates when the meter is powered, or electrical shock and explosion hazard can be caused.

Thread Connections

1. To protect against leakage, seal all threads with an appropriate sealing compound. Make sure the sealing compound does not intrude into the flow path.
2. Make sure the arrow on the outlet is pointed in the direction of the flow.
3. Tighten the turbine onto the fittings. Use a wrench only on wrench flats.

Flange Connections

For standard product, the flange follows GB/T 9119-2000 (ISO 7005-1) RF (Raised Face).

Note: flange can be customized following other criterias.

Use a gasket between the meter flange and mating flange. Determine the material of the gasket based on the operating conditions and type of fluid.

Note: Do not over tighten the flange bolts. This may cause the gasket to be compressed into the flow stream and may decrease the accuracy of the meter.

Installation Dimensions

Thread or flange connection is used according to different flow models. See Figure 1, 2, 3 and Table 3 for detailed dimensions.

Figure 1: DN4-DN10 sensor structure

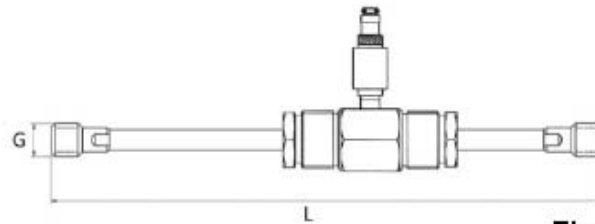

Figure 1

Figure 2: DN15-DN40 sensor Structure

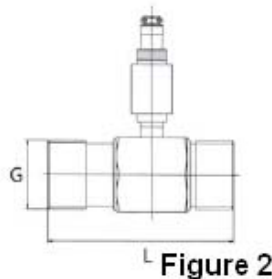

Figure 2

Figure 3: DN50-DN200 sensor structure

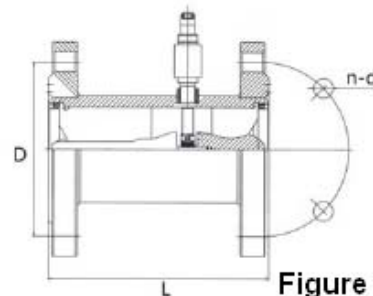

Figure 3

Table 3. Dimensions

Diameter (mm)	L (mm)	G	D (mm)	d (mm)	n (Bolts)
3.1 Flange: ISO7005-1 RF					
4	295	G ½	Threaded Connection		
6	330	G ½			
10	450	G ½			
15	75	G 1	Ø 65	Ø14	4
20	80	G 1	Ø 75	Ø14	4
25	100	G 1 ¼	Ø 85	Ø14	4
32	140	G 2	Ø100	Ø14	4
40	140	G 2	Ø110	Ø18	4
50	150	Flange Connection	Ø125	Ø18	4
65	170		Ø145	Ø18	4
80	200		Ø160	Ø18	8
100	220		Ø180	Ø18	8
125	250		Ø210	Ø22	8
150	300		Ø240	Ø22	8
200	360		Ø295	Ø28	12
3.2 Flange: ASNI Class 600					
15	90		Ø 66.5	Ø16	4
25	115		Ø 89	Ø20	4

Intelligent integrated Turbine Flow Meter (Type: LWGY- C)

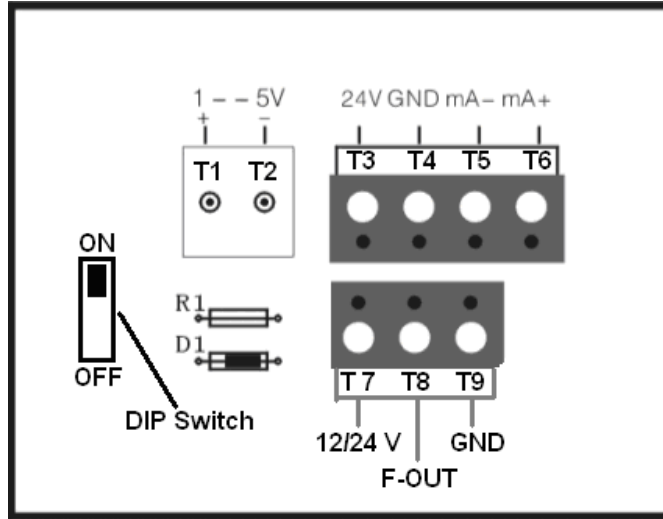

Figure 6. Terminal Wiring for LWGY- C

Table 5. Terminal wiring for LWGY- C

Function (Optional)	Terminal Symbols	Description
(2 wires) 4 to 20 mA Output	T3: 24V	Current Output 4 to 20 mA DC (+)
	T4: GND	Current Output 4 to 20 mA DC (-)
(3 wires) 4 to 20 mA Output	T3: 24V	24V+ DC Power Supply
	T4: GND	24V- DC Power Supply
	T6: mA+	Current Output 4 to 20 mA DC (+)
(4 wires) 4 to 20 mA Output	T3: 24V	24V+ DC Power Supply
	T4: GND	24V- DC Power Supply
	T5: mA-	Current Output 4 to 20 mA DC (-)
	T6: mA+	Current Output 4 to 20 mA DC (+)
Pulse Output	T7: 12/24 V	12/24V: 12V+ to 24V+ DC Power Supply
	T8: F-OUT	F-OUT: Pulse output
	T9: GND	GND: 24V- DC Power Supply
1 to 5V DC Output	T1: +	1 to 5V DC output (+)
	T2: -	1 to 5V DC output (-)
	T3: 24V	24V+ DC Power Supply
	T4: GND	24V- DC Power Supply

DIP Switch Function: (Default position: OFF)

ON: Terminal T4 (GND) connects to Housing, solving 50Hz interference.

OFF: Disconnect the connection between Terminal T4 (GND) and Housing.

Note: When multi flow meters are powered with same power supply, only one meter's DIP switch can be set at "ON" and others should be at "OFF" position.

6.0 ELECTRICAL WIRING





Warning: Electrical Hazard

Disconnect power before beginning installation.

Turbine Flow Sensor/Transmitter (Type: LWGY- N, LWGY- A)

Basic Type: LWGY- N (See Table 4)

Table 4. Terminal wiring for LWGY- N

Terminal Symbols	Description
Red Wire 	Power Supply: "24V+"
White Wire 	Power Supply: "24V-"
Yellow Wire 	Pulse Output

Explosion Proof Type: LWGY- N (See Figure 4)

Figure 4. Terminal configuration and terminal wiring for LWGY- N Explosion Proof Type

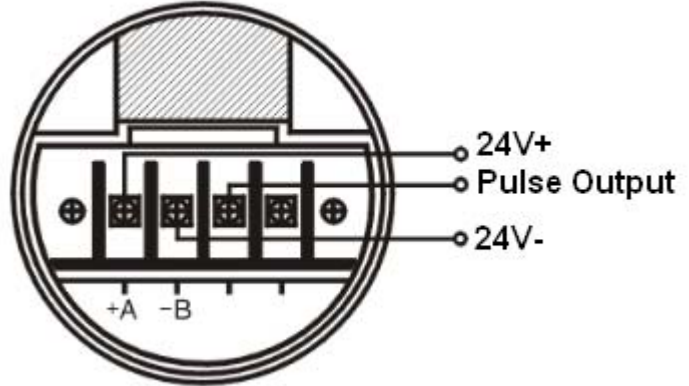

Explosion Proof Type: LWGY- A (See Figure 5)

Figure 5. Terminal configuration and terminal wiring for LWGY- A Explosion Proof Type

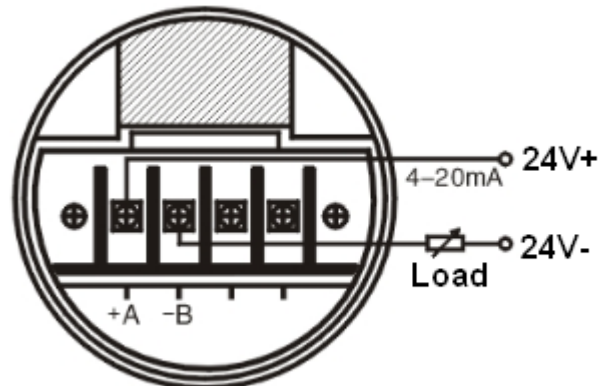

7.0 OPERATION AND SETUP

Basic Type: LWGY-□N Turbine Flow Sensor

The sensor has been calibrated and qualified prior to leave the plant. Connections between this sensor and secondary instrument: At first check whether the sensor's output characters (pulse's frequency, amplitude and width) can match secondary instrument's input characters. Set secondary instrument's parameter according to sensor's K-Factor.

A Type: LWGY- A Turbine Flow Transmitter

According to customer's requirement, the current output for zero and full-scale flow has been adjusted prior to leave the plant.

B Type: LWGY- B Intelligent Turbine Flow Meter

Parameter Setup: (Authorized Engineer only)

Warning: Don't change the parameter unless get the approval from distributor or Lekton company. Even minor change on parameter can affect accuracy.

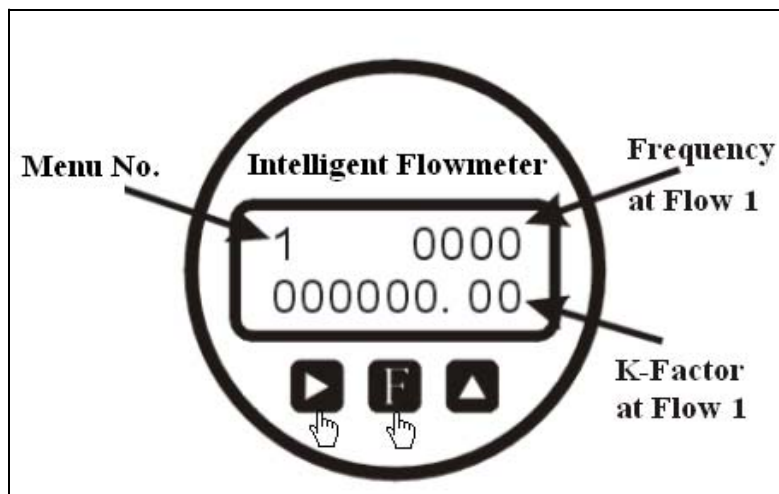



Figure 7. Enter Parameter Setup

To enter parameter setup, press and hold the  and  buttons until the display changes.

Press  to change cursor position: cursor-right

Press  to change value

Press  to advance to next menu.

Press and hold   to exit and save setting.

To reset totalizator flow, under working state press and hold  

C Type: LWGY- C Intelligent Turbine Flow Meter (4 to 20 mA output)

Parameter setup same as LWGY- B on Page 14. While C Type has totally 4 menus, and menu No.4 is the flow corresponding to 20 mA current output. See figure 8.

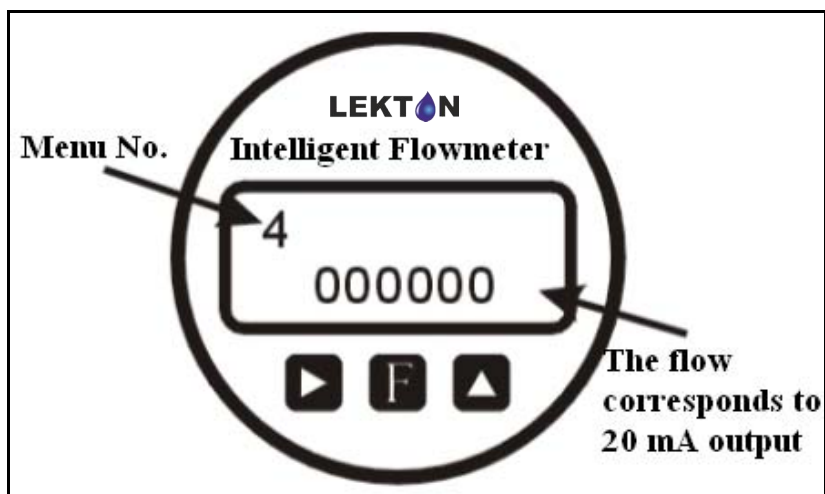

Figure 8. Menu No.4 for LWGY- C

8.0 TROUBLESHOOTING

Symptom	Probable Cause	Solution
Measurement is not accurate	<ol style="list-style-type: none"> 1. Turbine operated below minimum rate. 2. Turbine partially clogged with dried liquid 3. Installed too close to fittings. 	<p>Increase flowrate. Refer to Section 3.0 Operation Conditions</p> <p>Remove turbine. Clean carefully. Make sure rotor spins freely.</p> <p>Install correctly. Refer to Section 5.0 Cautions for Installation</p>
LCD Display Abnormity	<ol style="list-style-type: none"> 1. Battery Power Type: Bad contact on the connector between battery and PCB 2. DC Power Type: supply voltage is abnormal 	<p>Open back cover and repower the flow meter</p> <p>Check and ensure power supply is 24V DC</p>

9.0 METER CONSTRUCTION

